

Model: MT 160 HW

Data

Type: Hermetic piston compressors

Producer: Maneurop

Series: MT

Model: MT 160 HW

Technical data

Nominal motor power [kW]:	18,12
Cylinder count:	4
Displacement [m ³ /h]:	47,25
Cylinder capacity [cm ³]:	271,55
RPM [min ⁻¹]:	2900
Weight [kg]:	69
Oil charge [dm ³]:	3,9

Connections

	<u>milimeters</u>	<u>inches</u>
Króciec ssawny:		1 1/8"
Discharge line:		3/4"

Model: MT 160 HW

Capacity

R22

Cooling capacity [W]

$t_c \setminus t_e$	15	10	5	0	-5	-10	-15	-20	-25
30	71 010	59 250	48 960	40 030	32 360	25 820	20 310	15 720	11 950
40	63 640	52 840	43 410	35 250	28 250	22 310	17 300	13 120	9 660
50	55 740	46 000	37 560	30 290	24 090	18 850	14 460	10 810	-
60	47 390	38 840	31 500	25 240	19 960	15 550	-	-	-

Power input [kW]

$t_c \setminus t_e$	15	10	5	0	-5	-10	-15	-20	-25
30	9.29	9.39	9.30	9.04	8.64	8.13	7.53	6.86	6.15
40	11.37	11.19	10.84	10.35	9.75	9.06	8.31	7.52	6.72
50	13.52	13.02	12.38	11.63	10.79	9.88	8.95	8.00	-
60	15.68	14.82	13.86	12.80	11.69	10.54	-	-	-

Operating conditions: 11.1K suction superheat, 8.3K subcooling

t_c - Condensing temperature [°C]

t_e - Evaporating temperature [°C]

Model: MT 160 HW

Dimensions

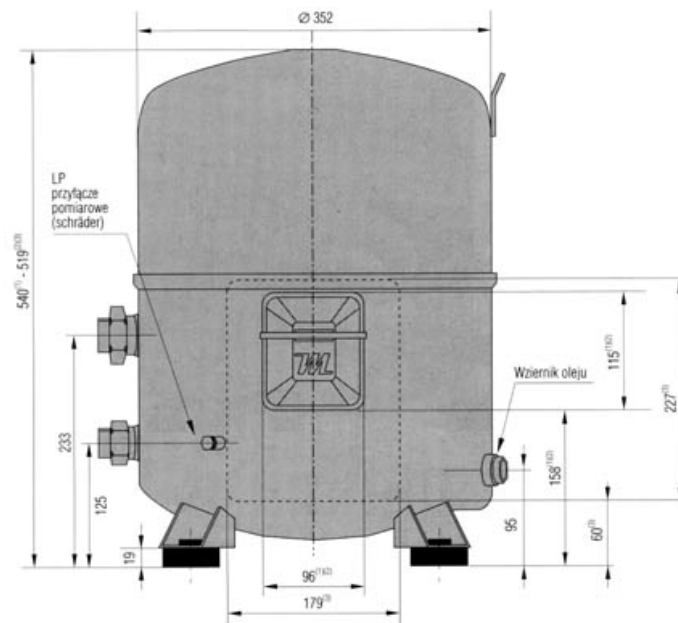
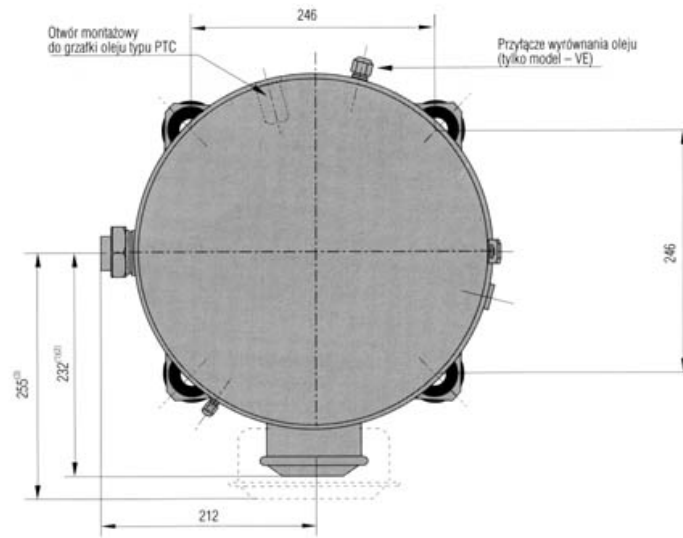

Model: MT 160 HW

Image

